

Isoclean®

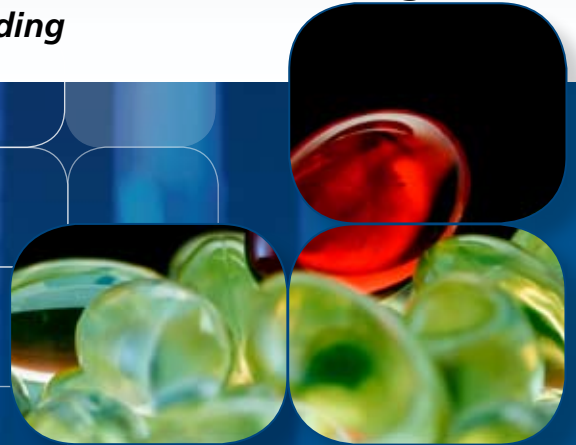

*Esco Isoclean Hospital Pharmacy Isolator,
Model HPI-4N.*

Hospital Pharmacy Isolator (Negative Pressure, Recirculating)
The Premium Solution for Sterile Drug Compounding





Main Features

- ULPA filters with a typical efficiency of 99.999% at 0.1 to 0.3 microns provide superior ISO Class 3 air cleanliness, 100 times better than competing products.

Sentinel Gold™ Microprocessor controller supervises all functions and monitors airflow and pressures in real-time.

Work zone and pass-thru are under negative pressure to the room in order to maintain operator protection in case of a breach in the barrier isolation system.

- Robust dual-wall construction. The work zone is surrounded by negative pressure plenums at the sides and back. Unique Esco Dynamic Chamber™ plenum surrounds filter seals with negative pressure.

Ergonomically angled front and oval gloveports improve reach and comfort.

- Safe-change cuff rings permit glove changes with zero risk of contaminating the work zone or pharmacy environment.

- One piece work zone liner with no crevices is easy to clean.

Esco **ISOCIDE™** antimicrobial coating on all painted surfaces minimizes contamination.

Sharps disposal system and hydraulic height-adjustable stand are available as options.

2

Available in 1.2 and 1.8 meters models (4' and 6'). Esco Isoclean Hospital Pharmacy Isolator, Negative Pressure, Recirculating, Model HPI-4N_ is shown with optional sharps disposal system and optional hydraulic height adjustable stand.



Isoclean®

Pharmacy Solutions • Negative Pressure, Compounding Aseptic Containment Isolator (CACI)

Vertical Pass Thru Door

The vertical pass-thru door prevents ingress of contamination into the work zone during transfer procedures. The built-in electrical interlock prevents both doors from being opened at the same time.



Horizontal Tray

The horizontal tray prevents operator fatigue during transfer procedures.



Airlock Pass-thru

The airlock pass-thru ensures work zone remains sterile during insertion and removal of items.



Optional Sharps Disposal System

Optional sharps disposal system enables smoother work flow and minimizes transfers in order to enhance patient protection and sterility. Sharps may be disposed through the work surface into disposal bins while minimizing contamination of the work zone.



Adjustable Hydraulic Support Stand

The motorized hydraulic stand may be adjusted for both sit-down or stand-up work position.

ESCO

WORLD CLASS. WORLDWIDE.



Product, Operator and Environment Protection

Esco Isoclean Hospital Pharmacy Isolators, Negative Pressure, Recirculating Models, provide a safe and clean environment for compounding of hazardous, sterile drug preparations in compliance with USP 797* criteria.

Barrier Isolation Systems

Barrier isolation system provide inherently superior sterility compared to open front clean air devices such as laminar flow clean benches and Class II biological safety cabinets. USP797 guidelines specify that isolators may be situated in an area subject to less severe environmental controls compared with open front clean air devices.

When used as part of a system that includes operator aseptic technique training, process validation, expiration setting, product quality maintenance after the CSP leaves the pharmacy, isolators are a cost-effective solution especially for lower-volume pharmacies. They reduce operating and renovation costs, take up less space, and are easier to maintain.

The negative pressure, recirculating HPI model is suitable for work involving hazardous materials, antineoplastic, or cytotoxic compounding applications. The work zone and pass-thru interchange are under negative pressure to the room in order to maintain operator protection in case of a breach in the barrier isolation system.

* United States Pharmacopoeia (USP), Chapter 797(1), enacted January 1, 2004, presents the first enforceable standards for sterile compounding. Following years of patient safety recommendations and professional guidelines, the intent of USP 797 is to set forth the procedural and practical requirements for safe compounding of sterile preparations. The Chapter's requirements are applicable in all practice settings where sterile preparations are compounded.

When hazardous drugs compounded have the potential to volatilize, the negative pressure, recirculating isolator should be ordered with the optional exhaust activated carbon filter and / or externally vented. Alternatively, a negative pressure, total exhaust isolator should be selected.

Maximum Patient Protection and Sterility

- The combination of downflow and exhaust ULPA filters gives the Esco Pharmacy Isolator a fully integrated envelope for product protection in all configurations.
- Advanced mini-pleated supply ULPA filter is tested to >99.999% efficiency for 0.1 to 0.3 micron particulates, significantly better than conventional HEPA filters.
- An improved mini-pleat separation technique maximizes filter surface area, improves efficiency and extends filter life over conventional separation.
- The ULPA supply filter provides clean air to the work surface in a gentle vertical laminar flow.
- Superior air cleanliness of ISO Class 3, 100 times better than competing products.

Mini-pleat Separatorless Filter (left) vs. Conventional Aluminium Separator Filter (right)



Esco cabinets use Swedish Camfil Farr® mini-pleat filters without aluminum separators to increase filter efficiency, minimize the chance of leakage, and to prolong filter life. Filters include a lightweight aluminum frame for structural stability and elimination of swelling common to conventional wood frames.

- Laminar (unidirectional) airflow within work zone and pass-thru enables recovery of chamber atmosphere to ISO Class 3 conditions within 3 minutes

following a worse-case contamination event. The entire work zone air is changed 20-30 times per minute. Refer to separate information on recovery testing carried out by Esco.

- Airlock pass-thru ensures work zone remains sterile during insertion and removal of items. Items are inserted into the pass thru, surface decontaminated, the outer pass thru door is closed, while the atmosphere is allowed to purge. Finally, the inner pass-thru vertical door is opened from within the work zone in order to transfer materials into the main work area.
- Vertical sliding door between pass-thru and work zone minimizes ingress of particulates from the pass-thru during transfer operations compared with conventional swing door designs.
- Optional sharps disposal system enables smoother work flow and minimizes transfers in order to enhance patient protection and sterility. Sharps may be disposed through the work surface into disposal bins while minimizing contamination of the work zone. Interface between sharps disposal bin and isolator is aerosol tight to avoid ingress of contamination during the disposal operation.



- Safe-change cuff ring enable glove change with zero risk of contamination.

Ergonomic Enhancements

Ergonomic enhancements minimize stress associated with long periods of operation.

- Ergonomically styled sloped front reduces glare and allows for easier reach into the work area.

Esco Filter Efficiency

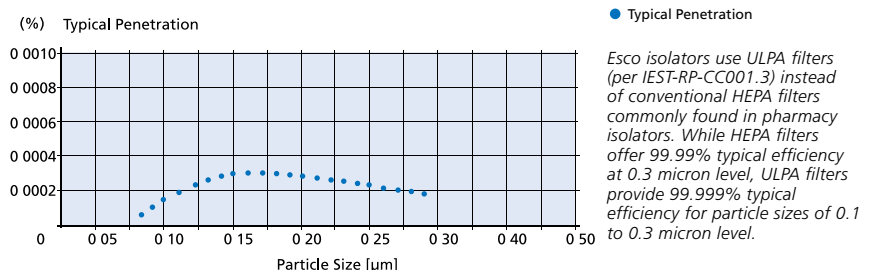

Enlarged, multi-line digital read-out with alpha-numeric display indicates all input, status and alarm functions.

Work zone, interchange pressures and downflow velocity are continuously measured and displayed. Integrated true airflow sensor is temperature compensated for improved accuracy.

Password-protected administration can be set to restrict access to main menu.

Color coded indicator lamps display green for fan operation; blue for fluorescent lights and electrical outlet; and orange for AUX function ON.

Optional audible and visual alarms warn of unsafe conditions such as low chamber pressure.

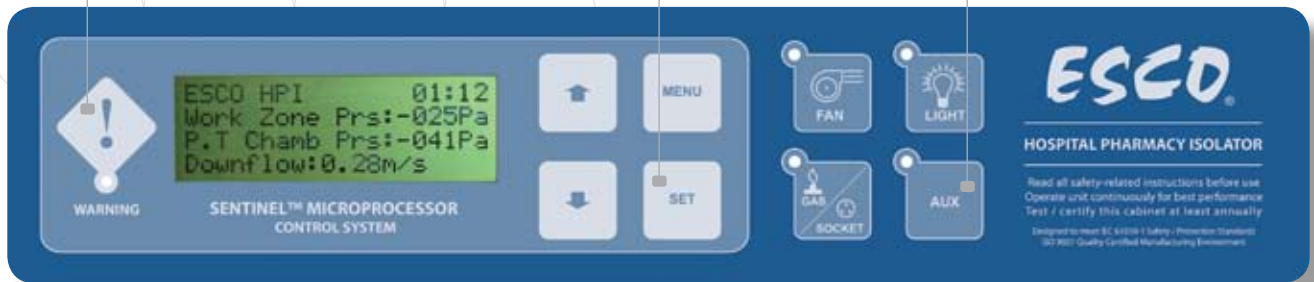

Sentinel Microprocessor Control System, Programmable

- When programmed ON
- the start-up sequence confirms status with Air Safe and local time display.
- the Personal Identification Number (PIN) access restricts unauthorized adjustments.

- Sliding tray facilitates material transfer without the operator having to reach into the pass-thru interchange area.
- Oval shaped gloveports improve reach into the work zone compared with conventional circular ports.
- Optional hydraulic stand allows the operator to adjust the work surface height to his / her height, for both sitting and standing operation.
- All common surgical gloves attach to cuff ring, thereby making the system adaptable to operator preference.
- Instant-start 5000k fluorescent lamps operate on electronic ballasts for energy efficiency. Lamps deliver > 950 Lux (> 88 foot-candles) to the work surface for superior overall illumination.

Cabinet Construction Designed for Easy Cleaning

Robust construction and enhanced safety features qualify the Esco Hospital Pharmacy Isolator for the most demanding laboratory applications. The isolator is fully assembled and ready to install and operate when shipped.

- The cabinet interior is constructed of durable and pharmaceutical-grade 304 stainless steel.
- Single-piece stainless steel work surface is easy to clean. Raised edges on all sides contain spillages.
- Stainless steel drain pan below the work surface contains spills.

- The interior work area is formed from a single piece of 304 stainless-steel with large radius corners to simplify cleaning.
- The cabinet work zone has no welded joints to collect contaminants or rust.
- Tray components lift and remove to provide easy access and encourage surface decontamination.
- The cabinet exterior structure is constructed of industrial-grade electrogalvanized steel.
- The downflow ULPA filter is protected by a diffuser which may be cleaned.
- There are no screws on the front or sides to trap contaminants or complicate cleaning.
- Hinged window may be opened for thorough access into the work zone.



The front visor opens up fully for maintenance access into the work zone.

- External surfaces are coated with Isocide antimicrobial coating to protect against surface contamination and inhibit bacterial growth. Isocide eliminates 99.9% of surface bacteria within 24 hours of exposure.
- Cleaning accessories available from Esco.

Sentinel™ Microprocessor Control, Monitoring System

The Esco Sentinel™ microprocessor-based control system supervises operation of all cabinet functions. Controls are configurable to meet user requirements. Features of the main control panel include:

- Work zone and pass-thru pressure is monitored and displayed on the LCD screen.
- Continuous monitoring and display of cabinet laminar (downflow) airflow on large, easy-to-read LCD display.
- An optional alarm package is available for users with more sophisticated requirements.

Blower Efficiency

The Hospital Pharmacy Isolator blower system is designed for maximum energy efficiency and minimal maintenance.

- Centrifugal, direct-drive, external rotor motors reduce operating costs.
- Unique Esco motor/blower orientations minimize noise and vibration.
- Built-in solid-state variable speed controllers are infinitely adjustable from Off to Maximum.

Hospital Pharmacy Isolator (Negative Pressure, Recirculating)

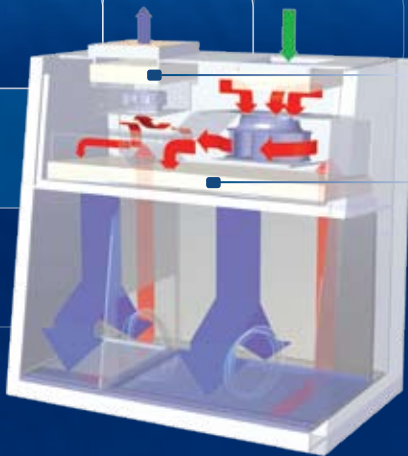

Exhaust ULPA filter
Supply ULPA filter

- Ambient air is pulled through the inlet pre-filter and 99.999% efficient filter located on top of the isolator. The pre-filter traps large size particles to extend the life of the 80% efficient filter.
- Air from the top inlet and from work zone is pulled by the main blower, which creates positive pressure on the plenum that creates downflow. Work zone pressure is always higher than the pass-thru, to prevent contaminants from entering the work zone through the pass-thru.
- The ULPA downflow filter creates a laminar and particle-free ISO Class 3 environment inside the isolator to protect the work material inside the main chamber and pass-thru.
- Air from the work zone and pass-thru is quickly purged out by the blowers to keep the area clean. The main blower pulls approximately 90% of the purged air back to the plenum and after passing through the ULPA downflow filter again, it is re-circulated back to the work zone and pass-thru. The high rate of airflow re-circulation helps to prolong filter life.
- Approximately 10% of the recirculated air is exhausted through an ULPA filter to prevent heat build-up inside the isolator. This exhausted air is replenished by ambient air coming from the top inlet pre-filter and 80% efficient filter.

- ULPA-filtered air
- Unfiltered / potentially contaminated air
- Room air / Inflow air

6

Standards Compliance	Cabinet Performance	Air Quality	Filtration	Electrical Safety
	CETA CAG-001-2005, USA CETA CAG-002-2006, USA USP CHAPTER 797, USA	ISO 14644.1, Class 3, Worldwide JIS B9920, Class 3, Japan JIS B55295, Class 3, Japan US Fed Std 209E, Class 1 USA	EN-1822, Europe IEST-RP-CC001.3, USA IEST-RP-CC007, USA IEST-RP-CC034.1, USA	UL-61010-1, USA CAN/CSA-22.2, No.61010-1 EN 61010-1, Europe IEC 61010-1, Worldwide

Safety and Certification

All components used in Esco products meet or exceed all applicable safety requirements.

- Each cabinet is individually factory tested for electrical safety.
- Documentation specific to the cabinet serial number is maintained on file.

Warranty

The Esco Pharmacy Isolator comes with a 3-year warranty excluding consumable

parts and accessories. Contact your local sales representative for specific warranty details.

Accessories and Options

Esco's Hospital Pharmacy Isolator is available as a standard bench top unit. Additional accessories are available for further enhancement.

Electrical Outlets and Utility Fittings

- Electrical outlet, ground fault, North America
- Electrical outlet, Euro/Worldwide

Support Stands

- Fixed height, available 711 mm (28") or 864 mm (34")
 - With leveling feet, ± 38.1 mm (1.5") (SAL-__0)
 - With casters (SPC-__0)
- Telescoping height stand for leveling feet (STL-__0), nominal range 660 mm to 960 mm (26" to 37.8")
- Telescoping height stand for casters (STC-__0), nominal range 660 mm to 880 mm (26" to 34.6")
 - Adjustable in 25.4 mm (1") increments
- Infinitely adjustable hydraulic stand, with casters elevates to seating or standing work surface height (SHM-_A0)

Other Options and Accessories

- Electrical outlets
- IV bar, with hooks
- All stainless steel construction
- Sharps disposal system
- Cleaning accessories
- Alarm package

Esco Centrifugal Fan with External Rotor Motor (left) vs. Conventional Fan with Standard Motor (right)

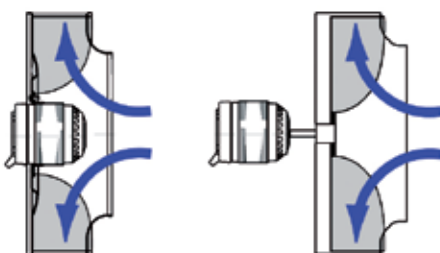

- Esco cabinets use German made *ebm-papst*[®] permanently lubricated, centrifugal motor/blowers with external rotor designs.
- Integrated blades narrow the profile and eliminate need for a motor shaft.
- Motors are selected for energy efficiency, compact design, and flat profile. The completely integrated assembly optimizes motor cooling.
- All rotating parts are unitized and balanced for smooth, quiet, vibration-free operation.

Isoclean[®]

Pharmacy Solutions • Negative Pressure, Compounding Aseptic Containment Isolator (CACI)

Glove Change Procedure

Step 1 Normal operating condition glove and sleeve inside the isolator.



Step 2 Pull sleeve and glove outside the isolator.



Step 3 Twist sleeve and tie-up the sleeve with cable tie.



Step 4 Remove glove.



Step 5 Place new glove into the sleeve.



Step 6 Fold glove over cuff ring and install spring.



Step 7 Release cable-tie.



Step 8 Procedure is complete.



- Exhaust carbon filter
- Thimble exhaust collar
- Perforated shelf to increase work zone space

Validated Performance

Comprehensive design qualification and factory acceptance tests are performed on the Esco Hospital Pharmacy Isolator.

- Filter Leak Tests verify the integrity of the ULPA filters as-installed.
- Downflow Velocity Tests verify adequate laminar air flow velocities and air change rates in the main chamber and pass-thru.
- Dynamic Pressure Test determines if main chamber and pass-thru pressures

are adequate to aid in providing separation between the main chamber and ambient environment. Glove-pull's are simulated to ensure differential pressure is maintained during actual operation.

- Particle Counts (Air Cleanliness Tests) verify air cleanliness in accordance with ISO 14644-1 criteria for both the main chamber and pass-thru.
- Product Ingress and Egress Tests determines if the isolator work zone can maintain ISO Class 3, during material transfers with no wait or purge time during the transfer process, when used outside an ISO Class 7 cleanroom, as per USP 797.
- Recovery Time Test determines the amount of time the main chamber takes

to recover to ISO Class 4 after an event such as a full window opening or large scale contamination.

- Gauntlet Breach Test determines product protection in case of a glove failure.
- Operator Comfort Tests include noise, light and vibration.

7



ISOCIDE™ Antimicrobial Powder-Coating

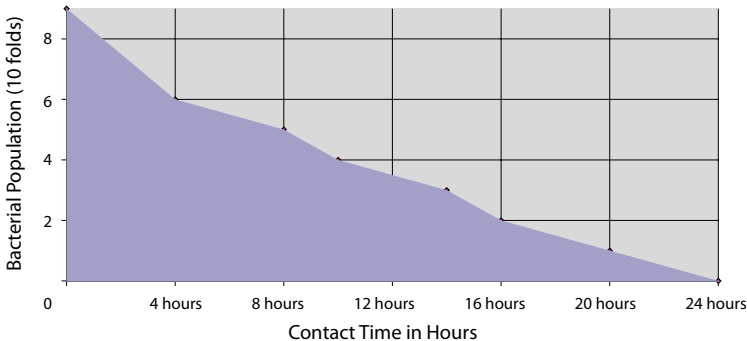

All exterior painted surfaces are powder-coated with Esco Isocide, an antimicrobial inhibitor to minimize contamination. Isocide is integrated into the coating substrate and cannot wash out or diminish by repeated cleaning. Performance results are available upon request. Contact Esco or your Esco Sales Representative for details.

ESCO

WORLD CLASS. WORLDWIDE.

Model HPI, Hospital Pharmacy Isolator (Negative Pressure Recirculating) Technical Specifications

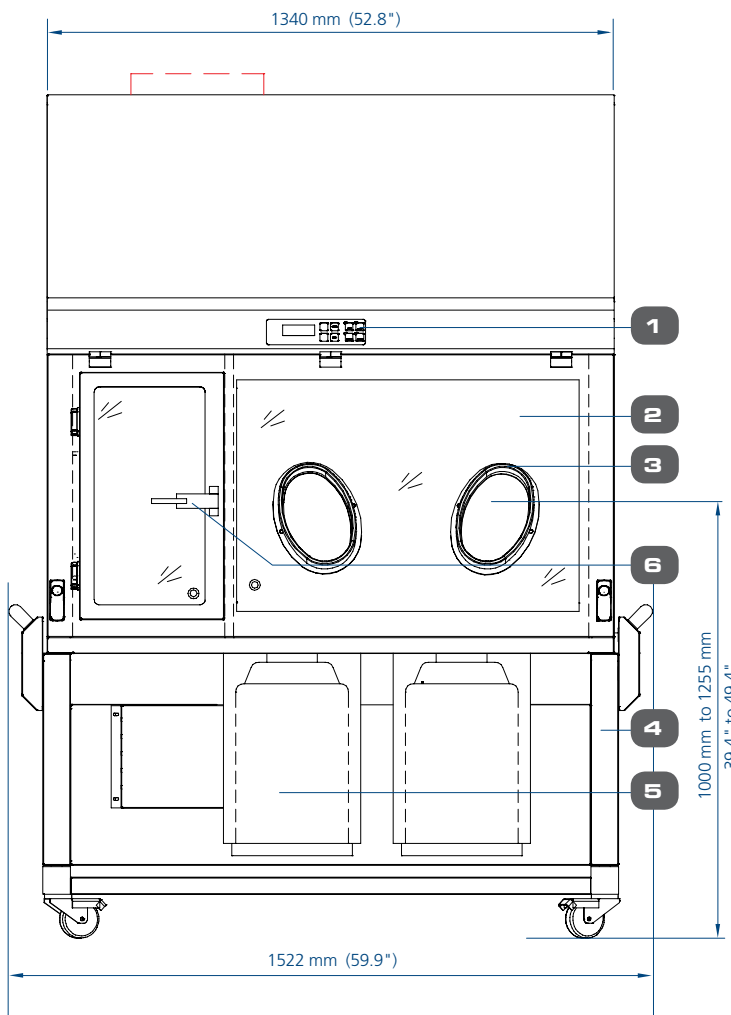
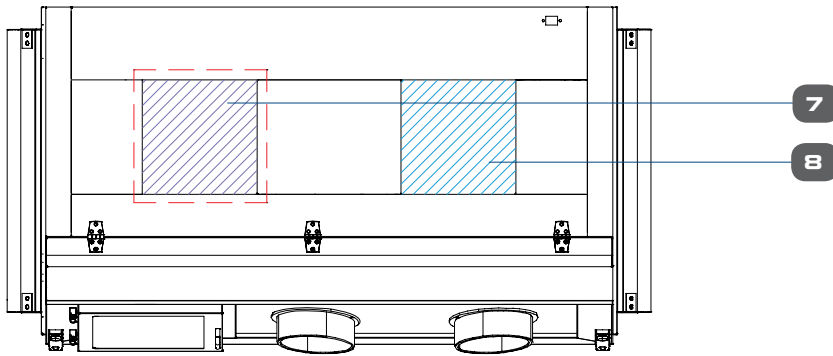

Model HPI-4N_ _ (2 Gloves)

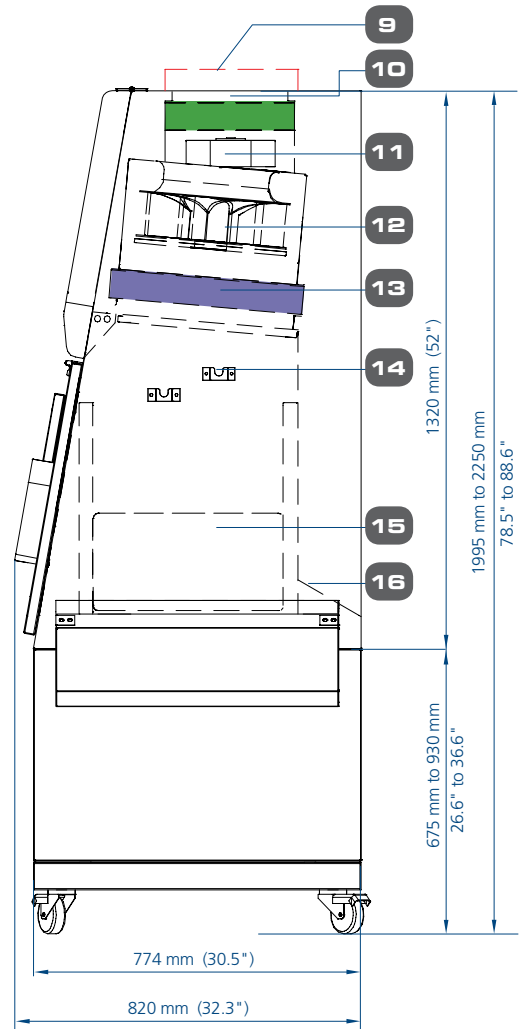

00

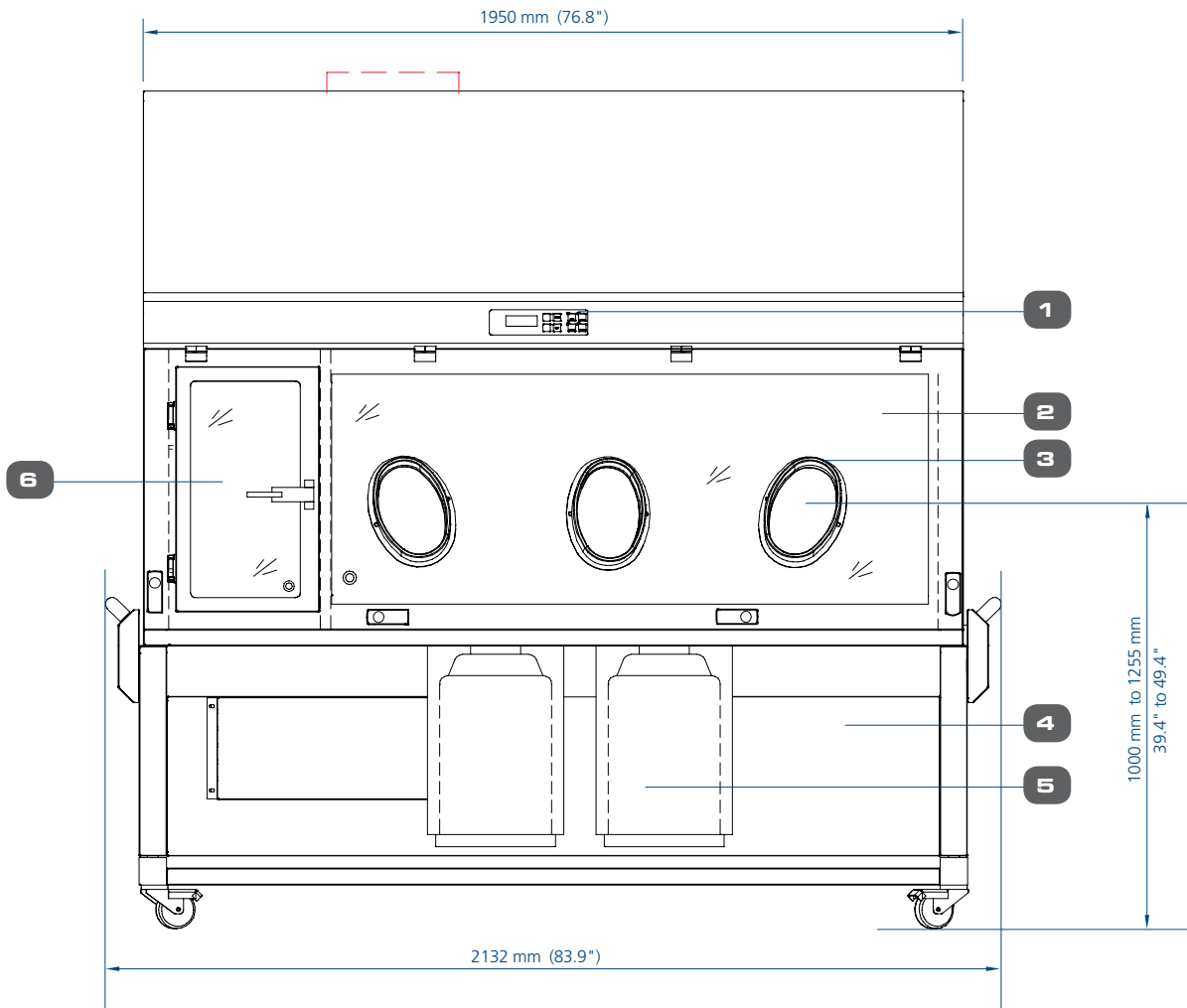
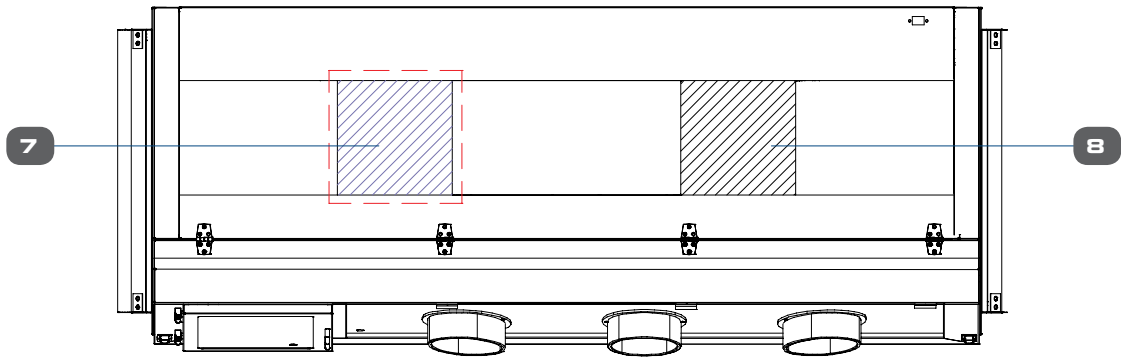

Model HPI-6N_-_ (3 Gloves)

- | | | |
|---|---------------------------------|---|
| 1. Esco Sentinel™ microprocessor control system | 6. Pass-thru, hinged outer door | 12. Blower |
| 2. Hinged front window | 7. Exhaust ULPA filter | 13. Downflow ULPA filter |
| 3. Oval glove ports | 8. Intake ULPA filter | 14. Staggered IV bar mounts |
| 4. Hydraulic height adjustable base stand with castors (optional) | 9. Carbon filter (optional) | 15. Pass-thru, inner door, vertical sliding |
| 5. Sharps/garbage disposal system (optional) | 10. Pre-filter | 16. Removable paper catch |
| | 11. Exhaust fan | |

General Specifications, Hospital Pharmacy Isolator, Negative Pressure Recirculating

Model		HPI-4N_ _
Nominal Size		1.2 meters (4')
External Dimensions (W x D x H)	Without Base Stand	1340 x 820 x 1320 mm (52.8" x 32.3" x 51.9")
	With Base Stand (Min)	1522 x 820 x 1995 mm (59.9" x 32.3" x 78.5")
	With Base Stand (Max)	1522 x 820 x 2250 mm (59.9" x 32.3" x 88.6")
Main Chamber Work Zone (W x D x H)		840 x 610 x 670 mm (33.1" x 24.0" x 26.4")
Pass Through (W x D x H)		355 x 610 x 670 mm (13.9" x 24.0" x 26.4")
Work Zone and Interchange Chamber Performance		ISO Class 3 (Class 1, Federal Standard 209E)
Inlet Filter Type		80% efficiency filter
Downflow and Exhaust Filter Type		ULPA filter with integral metal guards and filter frame gaskets; fully compliant with EN 1822 (H14) and IEST-RP-CC001.3 requirements (each cabinet has individual downflow and exhaust filters)
Typical Filter Efficiency		99.999% for particle size between 0.1 to 0.3 micron
Fluorescent Lamp Intensity		> 950 Lux (> 88 foot candles)
Isolator Construction	Main Body	1.2 mm (0.05") 18 gauge electrogalvanised steel with white oven-baked epoxy antimicrobial powder-coated finish
	Work Tray	1.5 mm (0.06") 16 gauge stainless steel, type 304, with 4B finish
	Side Walls	1.2 mm (0.05") 18 gauge stainless steel, type 304, with 4B finish
Electrical	220-240V, AC, 50Hz, 1Ø	HPI-4N1_ _
	Cabinet Power/ Amp	290 W/ 1.6 A
	Outlet Amp Fuse	5 A
	Total Amp	6.6 A
	BTU/ Hr	592
	220-240V, AC, 60Hz, 1Ø	HPI-4N3_ _
	Cabinet Power/ Amp	290 W/ 1.6 A
	Outlet Amp Fuse	5 A
	Total Amp	6.6 A
	BTU/ Hr	592
Shipping Dimensions, Maximum (W x D x H)*		1524 x 950 x 1600 mm (60" x 37.4" x 62.9")

* Pharmacy isolator only; excludes optional stand.

Models for Hospital Pharmacy Isolator (Negative Pressure Recirculating)

Model	Description
HPI-4N_0	4' Negative Pressure Isolator Only, No Sharps Provisions
HPI-4N_0-S*	4' Negative Pressure Isolator With Sharps Provisions
HPI-6N_0	6' Negative Pressure Isolator Only, No Sharps Provisions
HPI-6N_0-S*	6' Negative Pressure Isolator With Sharps Provisions

* If ordering isolator with sharps provisions, order the following to complete the selection. Only **2 sharps containers** can be mounted per isolator.

Sharps Disposal Containers

HPI-007	Sharp Disposal Container Complete With Mounting Base - 5.0qt (10.5" x 7.5" x 18")
---------	---

All HPI systems except HPI-4N_0 must be ordered with support stands. 5 types support stands available. Contact Esco Sales Representative for more informations.



Esco Containment, Clean Air and Laboratory Equipment Products

- Biological Safety Cabinets, Class II, III
- Fume Hoods, Conventional, High Performance, Ductless Carbon Filtered
- Laminar Flow Cabinets, Horizontal, Vertical, PCR
- Animal Containment Workstations
- Hospital Pharmacy Isolators, Cytotoxic Safety Cabinets
- Specialty Workstations: *In-Vitro* Fertilization, Powder Weighing
- PCR Thermal Cyclers, Conventional, Real-Time
- Cleanroom Fan Filter Units, Modular Rooms, Air Showers, Pass Thrus

Since 1978, Esco has emerged as a leader in the development of controlled environment, laboratory and cleanroom equipment solutions. Products sold in more than 100 countries include biological safety cabinets, fume hoods, ductless fume hoods, laminar flow clean benches, animal containment workstations, cytotoxic cabinets, hospital pharmacy isolators, and PCR cabinets and instrumentation. With the most extensive product line in the industry, Esco has passed more tests, in more languages, for more certifications, throughout more countries than any biosafety cabinet manufacturer in the world. Esco remains dedicated to delivering innovative solutions for the clinical, life science, research and industrial laboratory community. www.escoglobal.com.

NSF / ANSI 49 Biological Safety Cabinets • Animal Containment Workstations • Fume Hoods • Clean Benches



WORLD CLASS. WORLDWIDE.

Esco Technologies, Inc. • 2940 Turnpike Drive, Units 15-16 • Hatboro, PA 19040, USA
Toll-Free USA and Canada 877-479-ESCO • Tel 215-441-9661 • Fax 215-441-9660
us.escoglobal.com • usa@escoglobal.com

Esco Micro Pte. Ltd. • 21 Changi South Street 1 • Singapore 486 777
Tel +65 6542 0833 • Fax +65 6542 6920 • mail@escoglobal.com
www.escoglobal.com

Esco Global Offices | Singapore | Philadelphia, USA | Leiden, The Netherlands | Salisbury, UK
Kuala Lumpur, Malaysia | Beijing, Shanghai & Guangzhou, China | Mumbai, India | Manama, Bahrain



© 2008 Esco Micro Pte. Ltd. Specifications Subject to Change: ES1414_V1_IK_06/08